

Straight Threaded Well Assemblies

To order: To specify a complete assembly, indicate the code letter or value for each requirement. To order a well only, fill in only the boxes in brackets. Add a nipple or nipple-union-nipple to a well by including the extension code and "A" length in addition to the well codes.

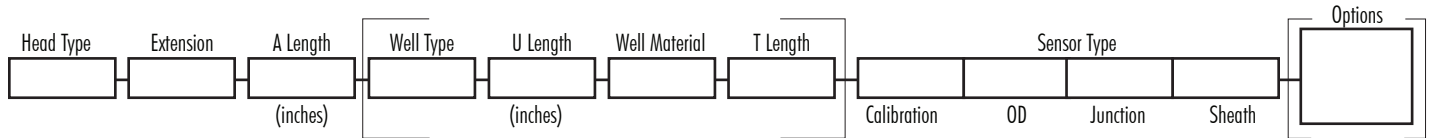

HEAD TYPE

0	No Head	EPA	Explosion Proof Aluminum
CA	Cast Aluminum	EPAA	Explosion Proof Aluminum Atex
CI	Cast Iron	EPS	Explosion Proof Stainless Steel
CSS	Cast Stainless Steel	EHA	Explosion Proof Aluminum
PPS	Polypropylene Sanitary	EHI	Explosion Proof Iron
FTA	Flip Top Aluminum		
FTP	Flip Top Poly (white)		

EXTENSION

N	Nipple Galvanized
NUN	Nipple/Union/Nipple Galvanized
NS	Nipple Stainless Steel
NUNS	Nipple/Union/Nipple Stainless Steel
HUNS	Hex Nipple/Union/Nipple Stainless Steel
PNUN	Pressure Seal in Union Galvanized
PNUNS	Pressure Seal in Union Stainless Steel

See page A-7 for additional information.

THERMOWELL

Well Type

Type	Process NPT	OD1
SS	1/2"	.680
SS0	3/4"	3/4"
SS1	1"	7/8"
SS2	1 1/4"	1 1/8"
SS3	1 1/2"	1 1/8"

Well Materials – For other materials, see page B-6.

A	Alloy 600	M	Monel® 400
AA	Alloy 20	N	Nickel
B	Hastelloy® B	P	304SS
C	Hastelloy® C	Q	310SS
D	321SS	R	316SS
F	347SS	S	Carbon Steel
H	446SS	T	Teflon®
I	Alloy 800	V	Alloy 825
LP	Low Carbon 304SS	W	Alloy 601
LR	Low Carbon 316SS	Y	Brass

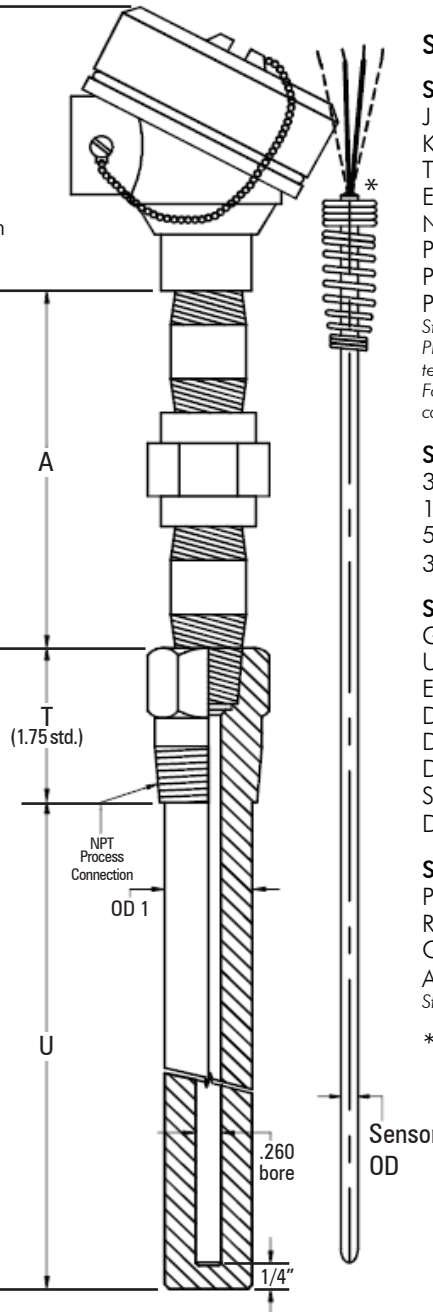

SENSOR TYPE

Sensor Calibration

J	Iron Constantan®
K	Chromel® Alumel®
T	Copper Constantan®
E	Chromel® Constantan®
N	Nicrosil® Nisil®
PO	Low Temp RTD to 500° F
PH	High Temp RTD to 900° F
PM	Heavy Duty RTD to 900° F

Standard RTD is a three-wire 100 ohm Platinum / .00385 Alpha. For higher temperature ranges - consult factory. For special limits on thermocouples, repeat calibration code, i.e. JJ.

Sensor OD

316	3/16"
14	1/4"
516	5/16"
38	3/8"

Sensor Junction

G	Grounded
U	Ungrounded
E	Exposed
DG	Dual Grounded
DU	Dual Ungrounded
DE	Dual Exposed
S	Single RTD
D	Dual RTD

Sensor Sheath Materials

P	304SS
R	316SS
Q	310SS
A	Alloy 600

Standard Sheath Material is 316SS.

* Epoxy Seal - Max. Temp. 300°F

OPTIONS

Sensor Options

GA	Class A
FW	Four Wire RTD
HV	High Vibration RTD (PM only)
CR	Cryogenic RTD (PM only)
CT	Compensated Terminals (EHA/EHI head only)

Thermowell Options

HTE	Hydrostatic Pressure Test External	TF	Teflon® Coating
HTI	Hydrostatic Pressure Test Internal	TC	Tungsten Carbide
NC	NACE Certification for Well	VC	Velocity Calculations
OC	Oxygen Cleaned	WB	.385 Bore
ST	Stellite® Coating	BC	Brass Plug and Chain
		SC	SS Plug and Chain

If other than .385 Bore is required, specify bore size.

Transmitter/Indicator Options

LCP	Programmable, RTD, FM
PT	Programmable FM
HC	Hart® Compatible
	Provide Range and Temp F/C
	See pages A-33 – A-34 for additional transmitter information.
LPI	Loop Temperature Indicator
	See pages A-33 – A-34 for transmitter and other options.
BPI	Battery Powered Indicator